

THE PHOTOGRAPHY OF SOUND-WAVES  
AND THE DEMONSTRATION OF THE  
EVOLUTIONS OF REFLECTED WAVE-  
FRONTS WITH THE CINEMATOGRAPH.

Introduction.

IN a paper published in the *Philosophical Magazine* for August 1899, I gave an account of some experiments on the photography of sound-waves, and their application in the teaching of optical phenomena. Since writing this paper I have extended the work somewhat and at a meeting of the Royal Society on February 15, 1900, gave an account of this work, and demonstrated certain features of wave motion with the cinematograph.

In the present article I propose to give a somewhat more extended account of the work, paying especial attention to the analogies between the sound-waves and waves of light.

In teaching the subject of optics we are obliged to resort to diagrams when dealing with the wave-front, and in spite of all that we can do, the student is apt to form the opinion that the rays are the actual entities, and that wave-fronts are after all merely conceptions.

The set of photographs illustrating this article will, I think, be of no small use to teachers in ridding the minds of students of the obnoxious rays, and impressing the fact that all of the common phenomena of reflection, refraction and diffraction are due simply to changes wrought on the wave-front.

Sound-waves in air were first observed and studied by Toepler, by means of an exceedingly sensitive optical contrivance for rendering visible minute changes in the optical density of substances. A very full description of the device will be found in Toepler's article (*Wied. Annalen*, cxxx.), while a brief account of it will be given presently.

The waves in question are the single pulses of condensed air given out by electric sparks. A train of waves would complicate matters too much, and for illustrating the optical phenomena which we are to take up would be useless.

The snap of the spark gives us just what we require, namely, a single wave-front, in which the condensation is considerable.

When seen subjectively, as was the case in Toepler's experiments, the wave-fronts, if at all complicated, as they often are, cannot be studied to advantage, as they are illuminated for an instant only, and appear in rapid succession in different parts of the field. By the aid of photography a permanent record of the forms can be obtained and studied at leisure. The first series of photographs, published in the *Philosophical Magazine*, were made with an apparatus similar to the one to be presently described; while most of those illustrating this article were made on a much larger scale by employing a large silvered mirror in place of the lens, an improvement due to Prof. Mach, of Prague, who has given much attention to the subject.

As it is a matter of no trouble at all to set up in a few minutes, in any physical laboratory, an apparatus for showing the air-waves subjectively, and as the method does not seem to be as well known as it deserves to be, a brief description of the "Schlieren" apparatus, as Toepler named it, may not be out of place.

The Apparatus.

The general arrangement of the "Schlieren" apparatus is shown in Fig. 1. A good-sized achromatic lens of the finest quality obtainable, and of rather long focus, is the most important part of the device. I have been using the object-glass of a small telescope figured by the late Alvan Clarke. Its diameter is five inches, and the focal length about six feet. I have no doubt but that a smaller lens could be used for viewing the waves, but

one of at least this size is desirable for photographing them.

The lens is mounted in front of a suitable source of light (in the present case an electric spark), which should be at such a distance that its image on the other side of the lens is at a distance of about fifteen feet.

The image of the spark, which we will suppose to be straight, horizontal, and very narrow, is about two-thirds covered with a horizontal diaphragm (*a*), and immediately behind this is placed the viewing-telescope. On looking into the telescope we see the field of the lens uniformly illuminated by the light that passes under the diaphragm, since every part of the image of the spark receives light from the whole lens. If the diaphragm be lowered the field will darken, if it be raised the illumination will be increased. In general it is best to have the diaphragm so adjusted that the lens is quite feebly illuminated, though this is not true for photographic work. Let us now suppose that there is a globular mass of air in front of the lens of slightly greater optical density than the surrounding air (*b*). The rays of light going through the upper portion of this denser mass will be bent down, and will form an image of the spark below the diaphragm, allowing more light to enter the telescope from this particular part of the field; consequently, on looking into the instrument, we shall see the upper portion of the globular mass of air brighter than the rest of the field. The rays which traverse the under part of "*b*," however, will be bent up on the contrary, forming an image of the spark higher up, and wholly covered by the diaphragm; consequently this part of the

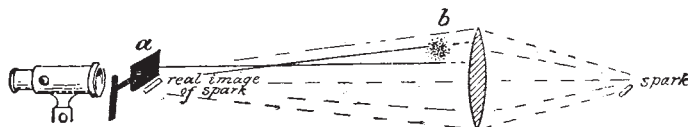

FIG. 1.

field will appear black. It will be readily understood that, with the long path between the lens and the image a very slight change in the optical density of any portion of the medium in front of the lens will be sufficient to raise or depress the image above or below the edge of the diaphragm, and will consequently make itself manifest in the telescope.

The importance of using a lens of first-class quality is quite apparent, since variations in the density of the glass of the lens will act in the same way as variations in the density of the medium before it, and produce unequal illumination of the field. It is impossible to find a lens which will give an absolute even, feeble illumination, but a good achromatic telescope objective is perfect enough for every purpose. A more complete discussion of the operation of the apparatus will be found in Toepler's original paper in the *Annalen*. The sound waves, which are regions of condensation, and consequent greater optical density, make themselves apparent in the same way as the globular mass of air already referred to. They must be illuminated by a flash of exceedingly short duration, which must occur while the wave is in the field of view.

Toepler showed that this could be done by starting the sound-wave with an electric spark, and illuminating it with the flash of a second spark occurring a moment later, while the wave was still in the field. A diagram of the apparatus used is shown in Fig. 2. In front of the lens are two brass balls (*a, a*), between which the spark of an induction coil passes, immediately charging the Leyden-jar *c*, which discharges across the gap at *e* an instant later. The capacity of the jar is so regulated that the interval between the two sparks is about one

ten-thousandth of a second. The field of the lens is thus illuminated by the flash of the second spark before the sound-wave started by the first spark has gone beyond the edge of the lens.

To secure the proper time-interval between the two sparks it is necessary that the capacity of the jar be quite small. A good-sized test tube half full of mercury standing in a jar of mercury is the easiest arrangement to fit up. This limits the length and brilliancy of the illuminating-spark, and with the device employed by Toepler I was unable to get enough light to secure photographs of the waves. After some experimenting I found that if the spark of the jar was passed between two thin pieces of magnesium ribbon pressed between two pieces of thick plate-glass, a very marked improvement resulted. With this form of illuminator I found that five or six times as much light could be obtained as by the old method of passing the spark between two brass balls.

The spark is flattened out into a band, and is kept always in the same plane, the light issuing in a thin sheet from between the plates. By this arrangement we secure a light source of considerable length, great intensity, and bounded by straight edges, the three essentials for securing good results. The glass plates, with the ribbon terminals between them, must be clamped in some sort of a holder and directed so that the thin sheet of light strikes the lens: this can be accomplished by darkening the room, fastening a sheet of paper in front of the lens, and then adjusting the plates so that the

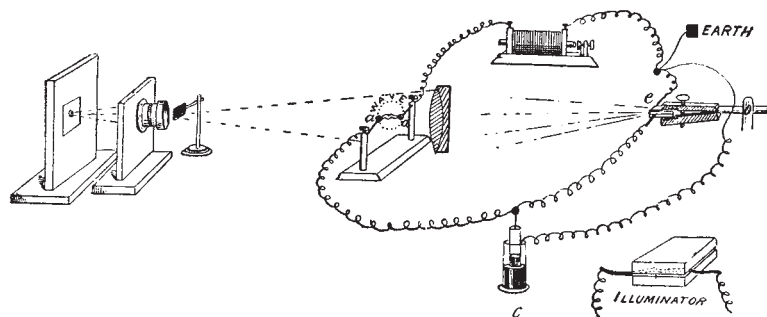

FIG. 2.

paper is illuminated as much as possible. The image formed by the lens will be found to have very sharp straight edges,<sup>1</sup> on one of which the edge of the diaphragm can be set in such a manner as to allow but very little light to pass when the intervening medium is homogeneous; a very slight change, however, in any portion may be sufficient to cause the entire amount of light passing through that portion to pass below the diaphragm and enter the telescope.

The photographs were made by substituting a photographic objective for the telescope, in the focal plane of which a vertical board was mounted to support the plate. The room was darkened, a plate held in position, and a single spark made to pass between the knobs by pulling a string connected with the hammer of the induction coil. The plate was then moved a trifle and a second impression secured in the same way. This obviated several of the difficulties experienced in the earlier work. The images never overlapped, and the hot air from the spark did not appear in the pictures. About thirty-five images were obtained on each plate in less than a minute, from which it was usually possible to pick a series showing the wave in all stages of its development, owing to the variations in the time-interval between the two sparks.

<sup>1</sup> If more than one image appears it means that the plane of the glass plates of the illuminator does not lie parallel to the optical axis of the system. It is of prime importance to secure a single image.

In the first series the pictures were so small that it was necessary to enlarge them several diameters. Those of the new series, owing to the use of an eight-inch mirror in place of the five-inch lens, and an objective of larger aperture and longer focus, required no enlarging.

*The Wave-Front Photographs.*

In the study of optics we may treat the subject of regular reflection in two ways, by rays and by wave-

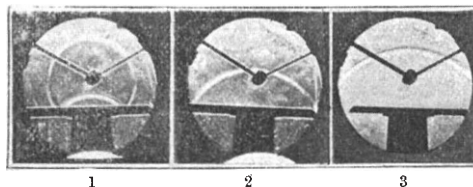

FIG. 3.

fronts. When spherical waves of light are reflected from a plane surface, we know that the reflected waves are also spherical in form, the centre of curvature being a point just as far beneath the reflecting surface as the source of light is above it. In the first of the series of photographs we have the reflection of a spherical wave of sound by a flat plate of glass, the wave appearing as a circle of light and shade surrounding the image of the balls, between which the spark passed (Fig. 3). The reflected wave or echo from the plate is seen to be spherical, with a curvature similar to the incident wave.

When we have a source of light in the focus of a parabolic mirror, the rays leave the mirror's surface parallel to one another, and move out in an intense narrow beam. Treating this case from the wave-front point of view, we ascertain by the usual geometrical construction that the spherical wave is changed by reflection into a plane or flat wave which moves out of the mirror without further divergence. In the picture (Fig. 4), only a portion of the parabolic reflector is shown near the bottom.

The sound-wave starts in the focus, and the reflected portion appears quite flat.<sup>1</sup>

What happens now if we use a spherical mirror in the same way?

Owing to the spherical aberration the reflected rays are not strictly parallel, or the reflected wave is not a true plane. Let us start a sound-wave in the focus of such a



FIG. 4.

mirror, and follow the reflected portion out of the mirror (Fig. 5). We notice that near the axis of the mirror the effect is much the same as in the case of the parabola, that is, the reflected front is plane. Thus we are

<sup>1</sup> In this series and some others left and right have been inadvertently interchanged by the engraver. The series should be followed by the numbers.

accustomed to say that if we confine ourselves to a small area around the axis, a mirror of spherical form acts

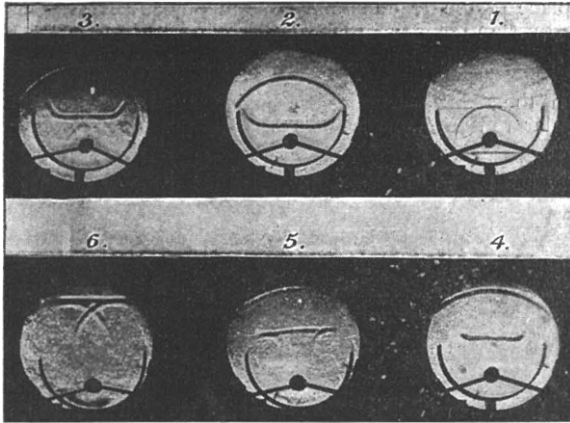

FIG. 5.

almost as well as a parabola. If on the contrary we consider the reflection from the entire hemisphere, we see that the reflected wave curls up at the edges, having a form not unlike a flat-bottomed saucer. The flat bottom moves straight up, travelling everywhere normal to its surface; but the curled up edges converge inwards, coming to a focus in the form of a ring around the flat bottom. This ring, of course, does not show in the photograph, which is a sectional view, but it will be seen that in one of the views (No. 4) the curved edge has disappeared entirely. In reality it is passing through a ring focus, and presently it will appear again on the other side of the focus, curved the other way, of course, and trailing along after the flat bottom. This curious evolution of the wave can be shown by geometrical construction, and I shall show later how its development can be shown with the cinematograph.

When the spherical waves start in one focus of an elliptical mirror, they are transformed by reflection into converging spheres, which shrink to a point at the other focus, the surface being aplanatic for rays issuing from a point. An elliptical mirror was made by bending a strip (Fig. 6) of metal into the required form, and a sound-wave started at one of the foci. The transformation of the diverging into a converging sphere, and the shrinkage of the latter to a point at the other focus, is well shown (Fig. 6).

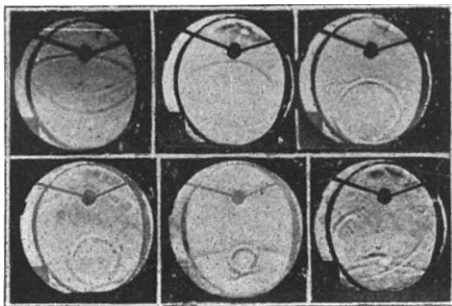

FIG. 6.

We will consider next another case of spherical aberration. When parallel rays of light enter a concave

mirror, those reflected from points of the mirror near its axis converge approximately to a point situated halfway between the surface of the mirror and its centre of curvature. The wave-front in the case of parallel rays is, of course, plane, and is changed by reflection into a converging shell of approximately spherical curvature. If we investigate the case more carefully, we find, however, that the reflected rays do not come accurately to a focus, but envelope a surface known as the caustic—in this case an epicycloid. The connection between the wave-front and the caustic is perhaps not at once apparent. Let us examine the changes wrought on a sound-wave entering a concave hemispherical mirror (Fig. 7).

If we follow the wave during its entrance into the mirror, we see that the reflected portion trails along behind, being united to the unreflected part at the mirror's surface. After the reflection is complete, we find the reflected wave of a form not unlike a volcanic cone with a large bowl-shaped crater (No. 4). This bowl-shaped portion we may regard as a converging shell, which shrinks to point at the focus of the mirror. As it shrinks, the steep sides of the cone run in under the bowl, crossing at about the moment when the converging portion is passing through the focus (No. 6). The rim of the crater forms a cusp on the wave-front, and if we follow this cusp we shall see that it traces the

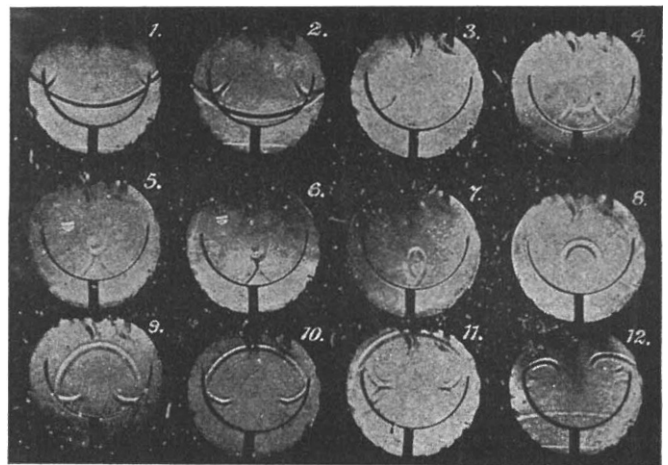

FIG. 7.

caustic surface. Hence we may define the caustic as the surface traced by the cusp of the wave-front.

The portion of the wave which comes to a focus at once begins to diverge again, uniting with the sides of the crater, the whole moving out of the mirror in a form somewhat resembling a mushroom or the bell of a Medusa jelly fish. The turned-under edges of the bell are cusped, and these cusps trace the caustic enveloped by the twice-reflected rays. These forms can also be constructed geometrically.

A much more complicated case is now shown (Fig. 8). Here the wave starts within a complete sphere, or rather cylinder. (Cylindrical surfaces have been used in all these cases for obvious reasons, the sectional views shown in the photographs being the same for both forms of surface.) Starting in the principal focus of the closed mirror, the wave is bounced back and forth, becoming more complicated after each reflection, yet always symmetrical about the axis. Only a few of the many forms are shown, and, with the exception of the first three or four, are not arranged in order; for at the time that the series was arranged on the slide this case had not been

worked out geometrically, and it was quite impossible to determine the evolution of the different forms. More recently this case has been constructed for five reflections, and all of the forms shown in the photographs found.

We will take up next some cases of refraction, the first

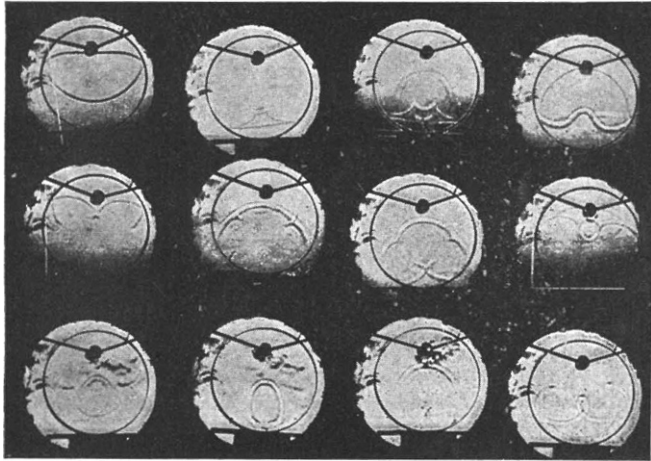

FIG. 8.

being that of a spherical wave at a flat surface of a denser medium. In Fig. 9 we have a rectangular tank with sides made of plane-parallel glass, and covered with a collodion film of soap-bubble thickness made by the method described by Toepler. Ordinary collodion is diluted with about ten parts of ether, poured on a small piece of plate-glass and immediately drained off. As soon as it is quite dry, a rectangle is cut with a sharp knife on the film. Toepler's method of removing the film was to place a drop of water on one of the cuts, and allow it to run in by capillarity; but I have had better success by proceeding in the following manner:—One end of the plate is lowered into a shallow dish of water, and the plate inclined until the water comes up to one of the cuts. By looking at the reflexion of a window in the water, it is possible to see whether the film commences to detach itself from the glass. If all goes well, it will float off on the surface of the water along the line of the knife-cut, and it should be slowly lowered (one

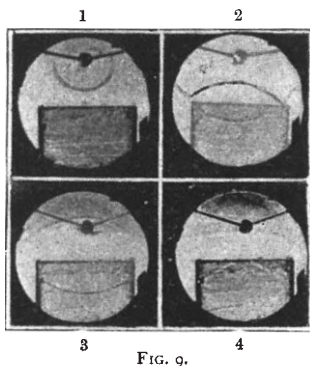

FIG. 9.

end resting on the bottom of the dish) until the rectangular piece detaches itself and floats freely on the surface. The edges of the tank are well greased, and then lowered carefully upon the film, to which they will adhere. The whole must then be lifted from the water in an oblique direction, when the film will be found

NO. 1606, VOL. 62]

covering the tank and exhibiting the most beautiful interference-colours. The tank was filled with carbonic acid and placed under the origin of the sound-wave. On striking the collodion film, the wave is partly reflected and partly transmitted, and it will be seen that the reflected component in air has moved farther than the transmitted component in the carbonic acid. The spherical wave-front is transformed into an hyperboloid on entering the denser medium. This is well shown in No. 3 of the series. In No. 4 the wave is seen in air, having been reflected up from the bottom of the tank.

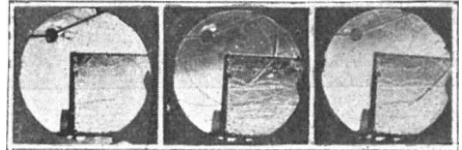

FIG. 10.

In Fig. 10 we have the refraction of the wave in the same tank under oblique incidence. The bending of the wave within the tank is very marked. The wave-fronts reflected from the side which follows the unreflected portion is also interesting in connection with Lloyd's single mirror interference experiment (No. 2 of series).

After several failures I succeeded in constructing a prism with its two refracting faces of this exceedingly

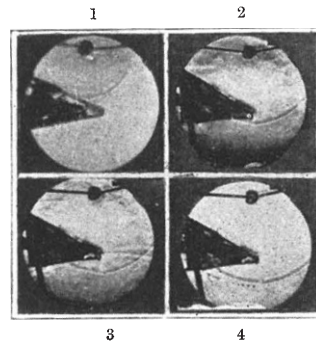

FIG. 11.

thin collodion, which, when filled with carbonic acid, showed the bending of the wave-front, exactly as we figure it in diagrams for light. It was necessary to have the collodion thinner than before, since if we are to photograph the wave after twice traversing the film, we must lose as little energy as possible by reflexion.

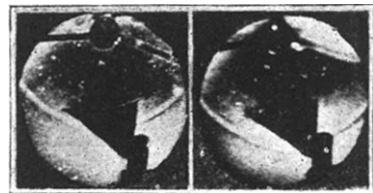

FIG. 12.

Fig. 11 shows the refraction in a carbonic acid prism, the bending being particularly noticeable in No. 4, on which I have, with a pair of dividers, traced out the position which the wave-front would have occupied had it not traversed the prism.

The bending of the wave-front in the opposite direction is shown in Fig. 12, where the same prism is filled with hydrogen gas, in which sound travels faster than in air.

In the next figure we have a very interesting case, though, owing to the experimental difficulties, the photographs are not quite as satisfactory as some of the others. It represents the transformation of a spherical into a plane wave by passage through a double convex lens.

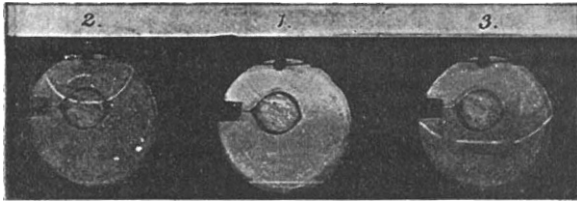

FIG. 13.

The construction of the cylindrical lens of exceedingly thin collodion was a matter of great difficulty. The flat, circular ends were made of thin mica as free from striæ as possible, that the passage of the wave through the lens could be followed. On these discs the collodion film was wound, the whole forming a hollow drum, which

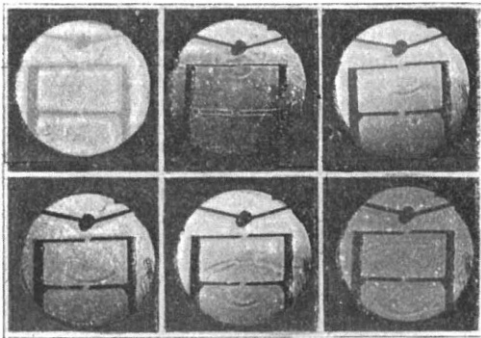

FIG. 14.

was then filled with carbonic acid. The sound-wave, started at the principal focus of this lens, is seen to be quite flat after its emergence (Fig. 13).

We will next take up some cases of diffraction, beginning with the well-known principle of Huygens, that any small portion of a wave-front can be considered as the

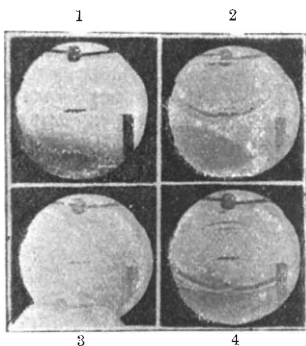

FIG. 15.

centre of a secondary disturbance, and that a small portion of this secondary disturbance can act as a new centre in its turn.

In Fig. 14 we have the wave starting above a plate with a narrow slit in it. This slit is seen to be the centre of a secondary hemicylindrical wave which moves down precisely as if the spark were located at the slit. After

proceeding a short distance this secondary wave encounters a second slit, and the same thing happens as before, the little slice that gets through spreading out into a complete wave, while the intercepted portion bounces back and forth between the plates.

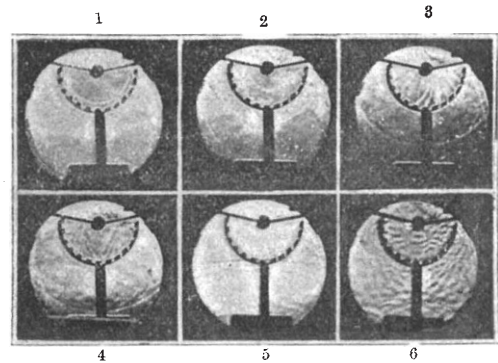

FIG. 16.

Fig. 15 shows the very limited extent to which sound shadows are formed. The wave is intercepted by a small glass plate. Just below the plate in No. 3 of the series a gap in the wave is found, which constitutes a shadow.

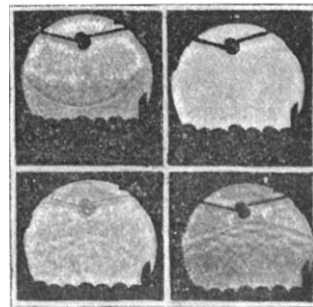

FIG. 17.

But presently, by diffraction, the wave curls in, closing up the gap and obliterating the shadow entirely. In the last one of the series it is interesting to note how the diffracted waves have their centres at the edges of the

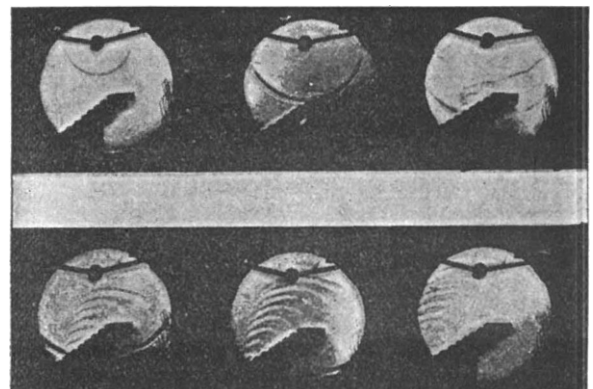

FIG. 18.

obstacle, the edges acting as secondary sources, as in the case of the diffraction of light.

The passage of a wave through a diffraction grating is shown in Fig. 16. The grating is made of strips of glass

arranged on a cylindrical surface, the wave starting at the centre of curvature. In No. 2 of the series the union of the secondary disturbances coming from the openings

constructions to aid in unravelling some of the complicated forms reflected from surfaces of circular curvature, that a very vivid idea of how these curious wave-

fronts are derived one from another could be obtained if a complete series could be prepared on the film of a cinematograph, and projected in motion on a screen.

Having been unable to so control the time-interval between the two sparks that a progressive series could be taken, I adopted the simpler method of making a large number of geometrical constructions, and then photographing them on a cinematograph film.

As a very large number of drawings (100 or so) must be made if the result is to be at all satisfactory, a method is desirable that will reduce the labour to a minimum. I may be permitted to give, as an instance, the method that I devised for building the series illustrating the reflection of a plane wave in a spherical mirror. The construction is shown in Fig. 19.

ABC is the mirror, AOC the plane wave. Around points on ABC as centres describe circles tangent to the wave. These circles will be enveloped by another surface, ADE, below the mirror (the orthogonal surface). If we erect normals on this surface, we have the reflected rays, and if we measure off equal distances on the normals, we have the reflected wave-front. By drawing the orthogonal surface we avoid the complication of having to measure off the distances around a corner. The orthogonal

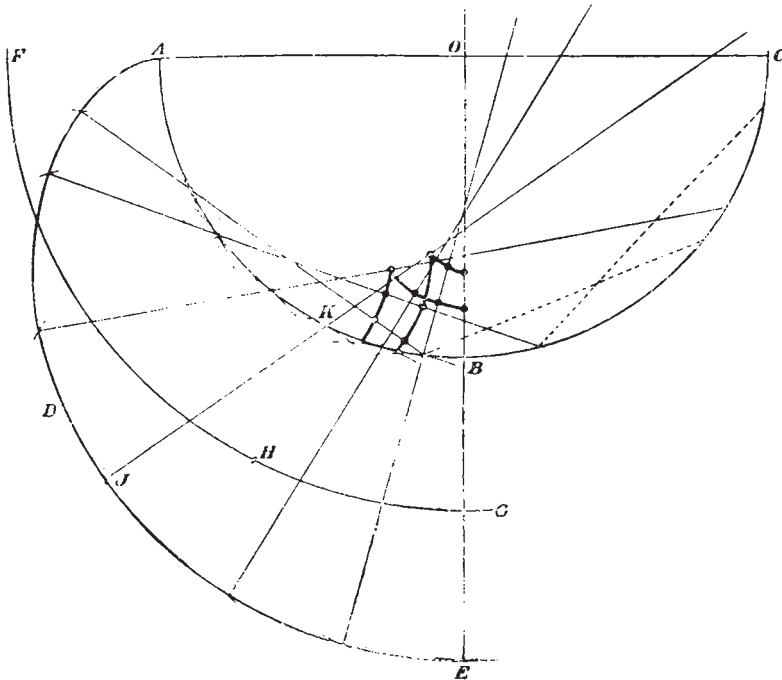

FIG. 19.

into a new wave-front is beautifully shown. In No. 3 the reflected wavelets have converged to the centre, but as each one is a complete hemicylinder, we see them radiating from the centre. This form can be constructed by describing semicircles around points on a circle of such radius that they all pass through the circle's centre. These semicircles represent secondary wavelets starting simultaneously from the various grating elements. In the last three pictures of the series the wave passes down, strikes the table, and is reflected up again, and it is interesting to see how the medium is broken up into meshes by the crossing and recrossing of the secondary waves.

Fig. 17 shows the form of the secondary wavelets formed by the reflection of a wave from a corrugated surface, and is interesting in connection with reflection gratings.

The formation of a musical note from a flight of steps is shown photographed in Fig. 18. This phenomenon is often noticed on a still night when walking on a stone pavement alongside a picket-fence, the sound of each footstep being reflected from the pailings as a metallic squeak, which Young has pointed out to be analogous to the power of a diffraction grating to construct light of a definite wave-length.

It occurred to me, while making some geometrical

the reflected wave-front. By drawing the orthogonal surface we avoid the complication of having to measure off the distances around a corner. The orthogonal

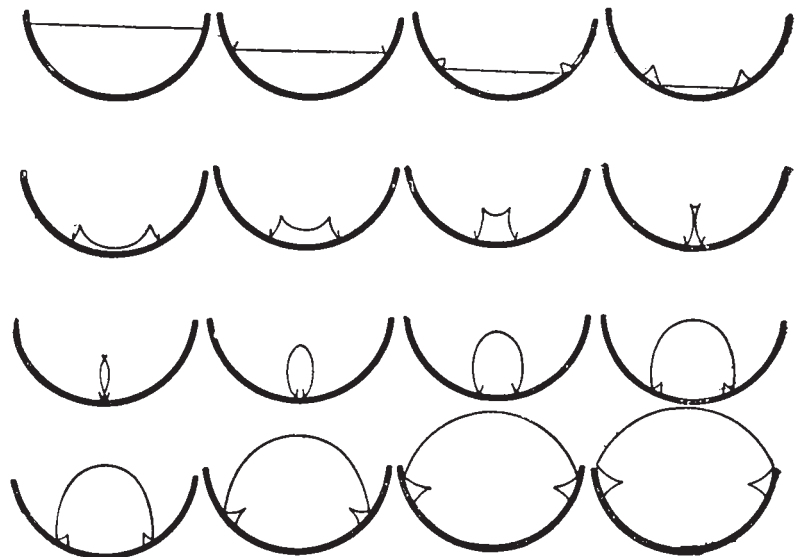

FIG. 20.

surface is an epicycloid formed by the rolling of a circle of a diameter equal to the radius of curvature of the mirror on the mirror's surface, and normals can be erected by drawing the arc FG (the path of the centre of

the generating circle), and describing circles of diameter BE around various points on it. A line joining the point of intersection of one of these circles with the epicycloid, and the point of tangency with the mirror, will, when produced, give a reflected ray; for example, JK produced for circle described around H. The construction once

cated by dotted lines), and measure around a corner each time.

About a hundred pictures are prepared for each series, and the pictures then photographed separately on the film, which, when run through the animatograph, give a very vivid representation of the motion of the wave-front.

Three films have been prepared thus far—reflection of a wave entering a concave hemispherical mirror (Fig. 20); reflection of a spherical wave starting in the principal focus of a concave hemispherical mirror (Fig. 21); and the reflection of a similar wave within a complete spherical mirror (Fig. 22). A number of these constructions, taken at

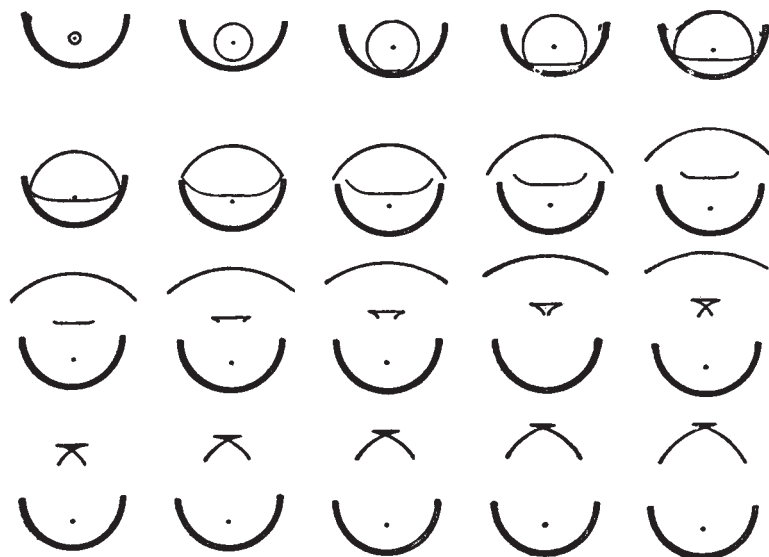

FIG. 21.

prepared, the series of wave-front pictures can be very quickly made. Three or four sheets of paper are laid under the construction, and holes are punched through the pile by means of a pin, at equal distances along each ray (measured from the orthogonal surface).

The centre of the mirror and the point where its axis

where the successive fronts are seen superposed. The former is for the reflection of a plane wave in a spherical mirror, the latter for the reflection of a spherical wave starting at the focus of a similar mirror. The caustic curve is shown by a dotted line in Fig. 23, and is seen to be traced by the cusps on the wave-fronts. The construction

shows that there is a concentration of energy at the cusp; consequently we may define the cusp as a moving

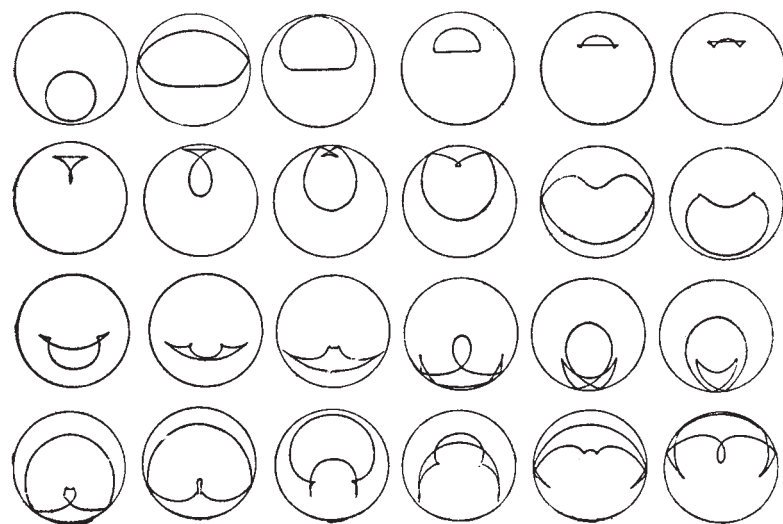

FIG. 22.

meets the surface are also indicated in the same manner. The sheets are now separated, and corresponding pin-holes are united on each sheet by a broad black line, which represents the wave-front. After a time it becomes necessary to consider double reflections, and to do this we are compelled to construct twice-reflected rays (indi-

so apparent, is at all novel, I may say that, so far as I have been able to find, it is not brought out in any of the text-books, caustic surfaces being invariably treated by ray rather than by wave-front methods.

The cinematograph series illustrating reflection inside a complete sphere was the most difficult to prepare, as



FIG. 23.

intervals along the film, are reproduced, and comparison of them with the actual photographs shows the close agreement between the calculated forms and those actually obtained.

I have already mentioned the fact that the cusps on the wave-fronts trace out the caustic surfaces. This is beautifully shown in Figs. 23 and 24, where the successive fronts are seen superposed. The former is for the reflection of a plane wave in a spherical mirror, the latter for the reflection of a spherical wave starting at the focus of a similar mirror. The caustic curve is shown by a dotted line in Fig. 23, and is seen to be traced by the cusps on the wave-fronts. The construction shows that there is a concentration of energy at the cusp; consequently we may define the cusp as a moving

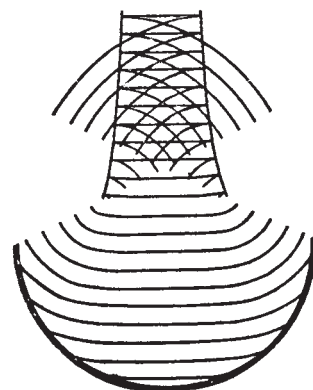

FIG. 24.

focus, and the caustic as the surface traced by it. Though I hesitate in claiming that this relation, at once

several reflections had to be considered. It has been completed for three reflections, and Mr. Max Mason, of Madison, to whom I am greatly indebted for his patient work in assisting me, is going on with the series. As will be seen, the wave has already become quite complicated, and it will be interesting to see what further changes result after three or four more reflections. I am also under obligations to Prof. A. B. Porter, of Chicago, who prepared the set of drawings illustrating the passage of a wave out from the principal focus of a hemispherical mirror.

R. W. WOOD.

#### NOTES.

MANY friends and admirers of the late Sir William Flower will be glad to know that a committee has been formed, with Lord Avebury as chairman, to secure the erection of a memorial to him. It is proposed that the memorial shall consist of a bust and a commemorative brass tablet to be placed in the Whale Room of the Natural History Museum—one of the departments in which he was most interested, and to which he devoted special care and attention. There should be a ready response to the invitation for subscriptions to carry out this scheme, for Sir William Flower's services to science are appreciated by every one interested in the extension of natural knowledge. The Natural History Museum ought not, indeed, to be without a memorial of the man who took such an active part in its development. Subscriptions (which must not exceed two guineas) should be paid to Dr. P. L. Sclater, treasurer of the Flower Memorial Fund, 3, Hanover Square, W.

IN the House of Commons on Tuesday, Mr. Goschen gave some particulars with regard to the Committee to inquire into the boilers of her Majesty's ships. The Committee will consist of seven members, and the president will be Vice-Admiral Sir Compton Domville. The other members of the Committee already chosen are Mr. List, superintending engineer of the Castle Company; Mr. Bain, superintending engineer of the Cunard Line; Mr. Milton, chief engineer surveyor of Lloyd's Registry of Shipping; Prof. Kennedy, formerly professor of engineering at University College; and, sixthly, an engineer of the Royal Navy holding the rank of an inspector of machinery. The seventh member of the Committee has not yet been selected. The instructions to the Committee are:—To ascertain practically and experimentally the relative advantages and disadvantages of the Belleville boiler for naval purposes as compared with the cylindrical boiler. To investigate the causes of the defects which have occurred in these boilers and in the machinery of ships fitted with them, and to report how far they are preventable either by modifications of details or by difference of treatment, or how far they are inherent in the system. Also to report generally on the suitability of the propelling and auxiliary machinery fitted in recent war vessels, and to offer any suggestions for improvement, stating at the same time the effect as regards weight and space of any alterations proposed. To report on the advantages and disadvantages of the Niclausse and Babcock and Wilcox boilers compared with the Belleville, as far as the means at the disposal of the Committee permit, and also to report whether any other description of boiler has sufficient advantages over the Belleville or the other two types mentioned, as a boiler for large cruisers and battleships, to make it advisable to fit it in any of her Majesty's ships for trial. For the purpose of making direct experiments between ships fitted with Belleville and cylindrical boilers respectively, the *Hyacinth*, fitted with Belleville boilers, will be placed at the disposal of the Committee. A cruiser of similar type fitted with cylindrical boilers will also be placed at the disposal of the Committee when required for the purpose of comparison.

NO. 1606, VOL. 62]

Mr. Goschen added that it is particularly desired that any conclusions the Committee may arrive at should be supported by experimental proof as far as possible, and that they should propose any further experiments which may be considered necessary for this purpose.

WE learn from the *Electrician* that a prize of 1000 francs (40*l.*) is being offered by the Association des Industriels de France contre les Accidents du Travail, 3, Rue de Lutèce, Paris, for the most efficacious insulating gloves for electrical workmen. They should be strong enough to resist not only the electric pressure, but also accidental perforations by copper wires, &c., and must, in addition, be easy to wear by hands of any size and allow the workmen's fingers sufficient freedom to execute their work. The competition is international, and competitors must send two pairs of gloves, accompanied by an explanatory note, to the president of the Association before December 31, 1900. The Association reserves to itself the right to publish descriptions of samples submitted to it, and inventors should therefore take the precaution of protecting their inventions previously.

A GLANCE through the addresses delivered at the meeting of the British Medical Association held at Ipswich last week, and published in the *British Medical Journal*, shows that leading members of the medical profession recognise the close relationship between medicine and other sciences. The president, Dr. W. A. Elliston, in an address in which he traced the developments of the science of British medicine and the evolution of the modern physician, remarked: "I am not unmindful of the up-to-date requirements of general culture—of an accurate knowledge of anatomy, chemistry, physiology, biology, bacteriology, pathology, physics, optics, mechanics, electricity and photography, which are all essential to the well-educated physician; they are daily called into requisition in order to diagnose and to direct the eye and hand in the treatment of disease." Similar acknowledgment of the dependence of medicine upon other sciences was made by Dr. Pye-Smith in his address abridged in another part of the present number. Mr. Frederick Treves, however, in his address on the progress of surgery during the last hundred years, ended his remarks with a sketch of the surgeon's place in the future, and expressed the hope that surgery might remain a handicraft, and that before all things the surgeon would strive to render his own hands self-sufficing, and not trust too much to diagnoses made for him in the laboratory. Short addresses were delivered by some of the presidents of the thirteen sections of the Association. In the section of pathology, Dr. E. E. Klein spoke upon bacteriology in relation to pathology, giving as illustrations of his theme the bacteriological work bearing upon inflammation, necrosis and cell secretions. Dr. Howard Marsh, in his address to the section of surgery, remarked: "Long a mere matter of routine, the treatment of fractures has lately felt the influence of modern advance in other departments of surgery. The Röntgen process secures an accuracy of diagnosis which formerly was often impossible." Dr. W. G. Smith made some suggestive remarks upon the teaching of pharmacology, pointing out some of the relationships between physiological action and chemical constitution. This fascinating subject has occupied the attention of several physiological chemists, and it offers numerous interesting problems for investigation.

WE learn from the *Athenaeum* that the 83rd Annual Meeting of the Swiss Natural Science Society will be held at Thüsis, Canton Grisons, from September 2-4. Three other Swiss scientific societies—the geological, the zoological, and the botanical—will hold their annual meetings at the same time and place. Intending guests are asked to communicate with the president, Dr. Lorenz, at Coire, as soon as possible. Prof. Forel, of Morges, will lecture at the general meeting of the